



**SCHMERSAL**

Version 2.0

**EN** Operating instructions. . . . . pages 1 to 12  
Original

3.7 Dimensions . . . . . 7  
3.7.1 Dimensions emitter and receiver SLC440COM . . . . . 7  
3.7.2 Dimensions emitter and receiver SLG440COM . . . . . 7  
3.8 Fixing . . . . . 8  
3.8.1 Included in delivery . . . . . 8  
3.8.2 Optional accessories . . . . . 8

**4 Rear side Electrical connection**  
4.1 Wiring example SLC/SLG440COM . . . . . 9  
4.2 Wiring example with safety-monitor module . . . . . 10  
4.3 Connector configuration Receiver, Emitter & Cable . . . . . 10

**5 Set-up and maintenance**  
5.1 Check before start-up . . . . . 10  
5.2 Maintenance . . . . . 10  
5.3 Regular check . . . . . 11  
5.4 Half-yearly inspection . . . . . 11  
5.5 Cleaning . . . . . 11

**6 Diagnostic**  
6.1 Status information . . . . . 11  
6.2 Fault diagnostic . . . . . 11

**7 Disassembly and disposal**  
7.1 Disassembly . . . . . 11  
7.2 Disposal . . . . . 11

**8 Appendix**  
8.1 Contact . . . . . 11

**9 EU Declaration of conformity**

**Content**

**1 About this document**  
1.1 Function . . . . . 1  
1.2 Target group: authorised qualified personnel . . . . . 1  
1.3 Explanation of the symbols used . . . . . 1  
1.4 Appropriate use . . . . . 2  
1.5 General safety instructions . . . . . 2  
1.6 Warning about misuse . . . . . 2  
1.7 Exclusion of liability . . . . . 2

**2 Product description**  
2.1 Purpose . . . . . 2  
2.2 Ordering code . . . . . 2  
2.3 Special versions . . . . . 2  
2.4 Included in delivery . . . . . 2  
2.5 Technical data . . . . . 2  
2.6 Response time (reaction time) . . . . . 3  
2.7 Safety classification . . . . . 3  
2.8 Functions . . . . . 4  
2.8.1 Protective mode / Automatic . . . . . 4  
2.8.2 Restart Interlock (operation) . . . . . 4  
2.8.3 Mode of operation - Restart Interlock - activate . . . . . 4  
2.9 Self-test . . . . . 4

**3 Mounting**  
3.1 General conditions . . . . . 4  
3.2 Protection field and approach . . . . . 4  
3.3 Alignment of the sensors . . . . . 5  
3.4 Setting mode . . . . . 5  
3.4.1 Setting mode with cable connection 5-pole . . . . . 5  
3.4.2 Setting mode with cable connection 4-pole . . . . . 5  
3.5 Safety distance . . . . . 5  
3.5.1 Minimum distance to reflecting surfaces . . . . . 6  
3.6 Mounting . . . . . 6

**1. About this document**

**1.1 Function**  
This operating instructions manual provides all the information you need for the mounting, set-up and commissioning to ensure the safe operation and disassembly of the safety switchgear. The operating instructions must be available in a legible condition and a complete version in the vicinity of the device.

**1.2 Target group: authorised qualified personnel**  
All operations described in this operating instructions manual must be carried out by trained specialist personnel, authorised by the plant operator only.

Please make sure that you have read and understood these operating instructions and that you know all applicable legislations regarding occupational safety and accident prevention prior to installation and putting the component into operation.

The machine builder must carefully select the harmonised standards to be complied with as well as other technical specifications for the selection, mounting and integration of the components.

**1.3 Explanation of the symbols used**

 **Information, hint, note:**  
This symbol is used for identifying useful additional information.

 **Caution:** Failure to comply with this warning notice could lead to failures or malfunctions.  
**Warning:** Failure to comply with this warning notice could lead to physical injury and/or damage to the machine.

### 1.4 Appropriate use

The products described in these operating instructions are developed to execute safety-related functions as part of an entire plant or machine. It is the responsibility of the manufacturer of a machine or plant to ensure the correct functionality of the entire machine or plant.

The safety switchgear must be exclusively used in accordance with the versions listed below or for the applications authorised by the manufacturer. Detailed information regarding the range of applications can be found in the chapter "Product description".

### 1.5 General safety instructions

The user must observe the safety instructions in this operating instructions manual, the country specific installation standards as well as all prevailing safety regulations and accident prevention rules.



Further technical information can be found in the Schmersal catalogues or in the online catalogue on the Internet: [www.schmersal.net](http://www.schmersal.net).

The information contained in this operating instructions manual is provided without liability and is subject to technical modifications.



The entire concept of the control system, in which the safety component is integrated, must be validated to EN ISO 13849-2.

There are no residual risks, provided that the safety instructions as well as the instructions regarding mounting, commissioning, operation and maintenance are observed.

Additional measures could be required to ensure that the system does not present a dangerous breakdown, when other forms of light beams are available in a special application (e.g. use of wireless control devices on cranes, radiation of welding sparks or effects of stroboscopic lights).

### 1.6 Warning about misuse



In case of improper use or manipulation of the safety switchgear, personal hazards or damages to machinery or plant components cannot be excluded. The relevant requirements of the standards EN ISO 13855 & EN ISO 13857 must be observed.



Only if the information described in this operating instructions manual are realised correctly, the safety function and therefore the compliance with the Machinery Directive is maintained.

### 1.7 Exclusion of liability

We shall accept no liability for damages and malfunctions resulting from defective mounting or failure to comply with this operating instructions manual. The manufacturer shall accept no liability for damages resulting from the use of unauthorised spare parts or accessories.

For safety reasons, invasive work on the device as well as arbitrary repairs, conversions and modifications to the device are strictly forbidden; the manufacturer shall accept no liability for damages resulting from such invasive work, arbitrary repairs, conversions and/or modifications to the device.

## 2. Product description

### 2.1 Purpose

The SLC/SLG440COM is a non-contact, self-testing safety guard which is used for the protection of hazardous points, hazardous areas and machine accesses. If one or more light beams are interrupted, the hazardous movement must be stopped.



The user must evaluate and design the safety chain in accordance with the relevant standards and the required safety level.

### 2.2 Ordering code

This operating instructions manual applies to the following types:

#### SLC440COM-ER-①-②

No.	Option	Description
①	xxxx	Protection field heights in mm available lengths: 0330, 0410, 0490, 0570, 0650, 0730, 0810, 0890, 0970, 1050, 1130, 1210, 1290, 1370, 1450, 1530*, 1610*, 1690*, 1770*, 1850*, 1930*
②	14	Resolution 14 mm with a range of 0.3 m ... 7 m
	30	Resolution 30 mm with a range of 0.3 m ... 10 m
	35	Resolution 35 mm with a range of 0.3 m ... 7 m

\* Resolution 14 mm:  
protection field height 1530 ... 1930 mm with a range of 0.3 m ... 6 m

\* Resolution 35 mm:  
protection field height 1850 ... 1930 mm with a range of 0.3 m ... 6 m

#### SLG440COM-ER-①

No.	Option	Description
①	0500-02	Distance between outermost beams: 500 mm, 2-beam
	0800-03	800 mm, 3-beam
	0900-04	900 mm, 4-beam • Range 0.3 m ... 12 m

### 2.3 Special versions

For special versions, which are not listed in the order code, these specifications apply accordingly, provided that they correspond to the standard version.

### 2.4 Included in delivery

- Sensors E, R (receiver with integrated status lamp)
- Mounting kit MS-1100
- Operating instructions DE/EN
- Spacer MSD5, from protection field height of 1050 mm

### 2.5 Technical data

Standards: EN 61496-1; EN 61496-2;  
EN ISO 13849; EN 62061

Material of the enclosure: Aluminium

Protection field heights:

- SLC440COM: 330 ... 1930 mm

- SLG440COM: 500 mm, 800 mm, 900 mm

Detection ability for test bodies:

- SLC440COM: 14 mm, 30 mm, 35 mm

- SLG440COM: 2 beams with resolution 500 mm <sup>1)</sup>

3 beams with resolution 400 mm <sup>1)</sup>

4 beams with resolution 300 mm <sup>1)</sup>

Range of the protection field:

- SLC440COM:

- Resolution 14 mm: Protection field height 330 ... 1450 mm: 0.3 ... 7.0 m  
Protection field height 1530 ... 1930 mm: 0.3 ... 6.0 m

- Resolution 35 mm: Protection field height 330 ... 1770 mm: 0.3 ... 7.0 m  
Protection field height 1850 and 1930 mm: 0.3 ... 6.0 m

- Resolution 30 mm: 0.3 ... 10.0 m

- SLG440COM: 0.3 ... 12.0 m

Response time: 1 - 48 beams = 10 ms

49 - 144 beams = 20 ms

145 - 192 beams = 28 ms

Rated operating voltage: 24 VDC ±10% (PELV) supply unit

$I_{max}$  1.0 A, to EN 60204 (power drop ≤ 20 ms)

Rated operating current: 200 mA max. + 2 x 0.25 A each OSSD

Wavelength of the infrared radiation: 880 nm

**Emitter, infrared emitted radiation**

- to DIN EN 12198-1:	Category 0
- to DIN EN 62471:	free group

**Safety outputs**

OSSD1, OSSD2:	2 x short-circuit proof PNP semi-conductor outputs
Test impulse cycle OSSD:	750 ms
Test impulse length:	150 µs
Switching voltage HIGH <sup>2)</sup> :	15 ... 26.4 V
Switching voltage LOW <sup>2)</sup> :	0 ... 2 V
Switching current each OSSD:	0 ... 250 mA
Leakage current <sup>3)</sup> :	1 mA
Load capacity:	0 ... 50 nF
Load inductance <sup>4)</sup> :	0 ... 2H
Function:	Protective mode / Automatic, Restart Interlock (manual reset), Setting mode
Status indication receiver:	end cap with integrated status indication: OSSD ON (green), OSSD OFF (red), alignment quality/restart mode (yellow)

**Connection:**

- Emitter:	Cable M12, 4-pole,
- Receiver:	Cable M12, 4-pole, 5-pole
Ambient temperature:	-10° C ... + 50° C
Storage temperature:	-25° C ... + 70° C
Protection class:	IP67 (IEC 60529)
Resistance to vibration:	10 ... 55 Hz to IEC 60068-2-6
Resistance to shock:	10 g, 16 ms, to IEC 60028-2-29
Year of construction:	as of 2014 version 2.0

<sup>1)</sup> Resolution = beam distance + beam diameter 10 mm

<sup>2)</sup> To IEC 61131-2

<sup>3)</sup> In case of failure, the leakage current flows to the OSSD cable.  
The downstream control element must recognise this state as LOW.  
A safety PLC must detect this state.

<sup>4)</sup> The load inductivity generates an induced voltage during the switch-off, which compromises the downstream components (spark quenching element).

**2.6 Response time (reaction time)**

The response time depends on the height of the protection field, the resolution, the number of light beams.

SLC440COM Resolution 14 mm			
Protection field height [mm]	Beams (lines) [Number]	Response time [ms]	Weight [kg]
330	32	10	0.5
410	40	10	0.7
490	48	10	0.8
570	56	20	0.9
650	64	20	1.0
730	72	20	1.1
810	80	20	1.3
890	88	20	1.4
970	96	20	1.5
1050	104	20	1.6
1130	112	20	1.7
1210	120	20	1.9
1290	128	20	2.0
1370	136	20	2.1
1450	144	20	2.2
1530	152	28	2.3
1610	160	28	2.5
1690	168	28	2.6
1770	176	28	2.7
1850	184	28	2.8
1930	192	28	2.9

SLC440COM Resolution 30 mm			
Protection field height [mm]	Beams (lines) [Number]	Response time [ms]	Weight [kg]
330	16	10	0.5
410	20	10	0.7
490	24	10	0.8
570	28	10	0.9
650	32	10	1.0
730	36	10	1.1
810	40	10	1.3
890	44	10	1.4
970	48	10	1.5
1050	52	20	1.6
1130	56	20	1.7
1210	60	20	1.9
1290	64	20	2.0
1370	68	20	2.1
1450	72	20	2.2
1530	76	20	2.3
1610	80	20	2.5
1690	84	20	2.6
1770	88	20	2.7
1850	92	20	2.8
1930	96	20	2.9

SLC440COM Resolution 35 mm			
Protection field height [mm]	Beams (lines) [Number]	Response time [ms]	Weight [kg]
330	11	10	0.5
410	14	10	0.7
490	16	10	0.8
570	19	10	0.9
650	22	10	1.0
730	25	10	1.1
810	27	10	1.3
890	30	10	1.4
970	33	10	1.5
1050	36	10	1.6
1130	38	10	1.7
1210	41	10	1.9
1290	44	10	2.0
1370	47	10	2.1
1450	49	20	2.2
1530	52	20	2.3
1610	55	20	2.5
1690	58	20	2.6
1770	60	20	2.7
1850	63	20	2.8
1930	66	20	2.9

SLG440COM			
Beams [Number]	Beam distance [mm]	Response time [ms]	Weight [kg]
2	500	10	0.8
3	400	10	1.3
4	300	10	1.4

**2.7 Safety classification**

Standards:	EN ISO 13849-1, EN 62061
PL:	up to e
Control category:	up to 4
PFH value:	8.05 x 10 <sup>-9</sup> / h
SIL:	up to 3
Service life:	20 years

### 2.8 Functions

The system consists of a receiver and an emitter. For the described functions, no further switching elements are required.

The system has the following operating modes:

- Protective mode automatic (factory setting)  
(automatic start after release of the protection field)
- Restart Interlock (manual reset)
- Setting mode

#### 2.8.1 Protective mode / Automatic

The protective mode switches the OSSD outputs to the ON state (protection field not interrupted), without external release of a switching device.



This operating mode may only be chosen in conjunction with the restart interlock (manual reset) of the machine.

#### 2.8.2 Restart Interlock (operation)

The restart interlock (manual reset) prevents an automatic enabling of the outputs (OSSD's ON state) after switch-on of the operating voltage or an interruption of the protection field. The system switches the outputs only to ON state, when an external command device (restart button) generates an enabling signal at the restart input (receiver).

#### 2.8.3 Mode of operation - Restart Interlock - activate

When delivered (factory setting) the operating mode Protection / Automatic is active. For the operating mode Restart Interlock, a 5 pole connection cable is needed for the receiver.

The operating mode Restart Interlock can be activated as follows:

- Remove power from the AOPD
- Move wire-link from OSSD1 to OSSD2 (Pin 2 and 4)
- When switching on the AOPD, apply +24V to the restart input (Pin 5), e.g. by pushing and holding down the restart interlock button of the command device.
- The AOPD indicates the current operating mode by the number of pulses on the integrated status indicator:  
**Automatic operating mode** = cyclic display of a pulse and pulse interval (red)  
**Restart interlock operating mode** = cyclic display of two pulses and pulse interval (red)
- Quickly pressing changes the operating mode ( $100 \text{ ms} < t < 1500 \text{ ms}$ ). The number of displayed light pulses (red) indicates the selected mode of operation.
- Keeping the restart button pressed stores the current mode of operation. This action is confirmed by the signal lamp rapidly flashing. Continue to hold down the restart button (for about another three seconds) until the AOPD has returned to its selected mode of operation (flashing the operation mode). To start the AOPD in the new mode remove power from the AOPD, remove the wire link between OSSD1 and OSSD2, and then reconnect power.



The command devices (enabling button) must be installed outside of the hazardous area. The operator must have a clear view on the hazardous area when actuating the enabling button.

### 2.9 Self-test

The system performs a complete self-test and safety test within 2 seconds after the operating voltage has been switched on. If the protection field is free, the system switches to the ON condition (automatic mode). In case of an error, the outputs at the receiver do not switch to the ON state.

During operation, the system executes a cyclic self-test. Safety-relevant faults are detected within the reaction time and cause the outputs to be switched off.

## 3. Mounting

### 3.1 General conditions

The following guidelines are provided as preventive warning notices to ensure a safe and appropriate handling. These guidelines are an essential part of the safety instructions and must therefore always be observed and respected.



- The SLC/SLG must not be used on machines, which can be stopped electrically in case of emergency.
- The safety distance between the SLC/SLG and a hazardous machine movement must always be observed and respected.
- Additional mechanical safety guards must be installed so that the operator has to pass by the protection field to reach the hazardous machine parts.
- The SLC/SLG must be installed so that the personnel always must be within the detection zone when operating the machine. An incorrect installation can lead to serious injuries.
- Never connect the outputs to +24VDC. If the outputs are wired to +24VDC, they are in ON state, as a result of which they are unable to stop a hazardous situation occurring on the application/machine.
- The safety inspections must be conducted regularly.
- The SLC/SLG must not be exposed to inflammable or explosive gasses.
- The connecting cables must be connected in accordance with the installation instructions.
- The fixing screws of the end caps and the mounting angle must be firmly tightened.

### 3.2 Protection field and approach

The protection field of the SLC/SLG consists of the entire range located between the protection field markings of transmitter and receiver. Additional protective devices must ensure that the operator has to pass by the protection field to reach the hazardous machine parts. The SLC/SLG must be installed so that the personnel is always located within the detection zone of the safety device when operating the hazardous machine parts to be secured.

#### Correct installation



Hazardous machine parts can only be reached after passing through the protection field.

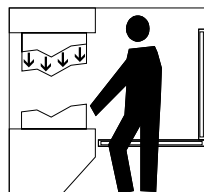

The presence of staff members between the protection field and hazardous machine parts must be prevented/avoided (protection against stepping over).

#### Unauthorised installation

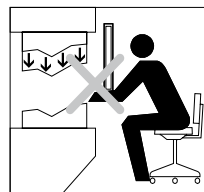

Hazardous machine parts can be reached without passing through the protection field.

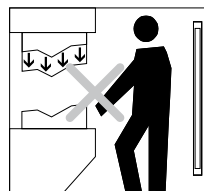

The presence of staff members between the protection field and hazardous machine parts is possible.

**3.3 Alignment of the sensors**

**Procedure:**

1. Transmitter and receiver must be fitted parallel to each other and at the same height.
2. Choose the operating mode "Automatic" (see chapter Protective mode/automatic) and switch the operating voltage on.
3. First rotate the transmitter, then the receiver to each other until the integrated status indicator lights up green. Adjust the transmitter and receiver so that they are in the middle of the angular range for a green indication. Fix the position with the two screws for each mounting bracket.

**3.4 Setting mode**

**3.4.1 Setting mode with cable connection 5-pole**

If +24 V is on the input (Pin 5, receiver) "Release restart" at system start for at least two seconds (by pressing the button restart), the system changes over to the setting mode of operation. In this mode the signal strength of the beam is signalled to the status indicator with the lowest value through light pulses (colour yellow). The better the alignment, the higher the frequency of the light pulses. The alignment is correct when the light pulses switch over to continuous light. If there is no optical synchronisation between the emitter and the receiver, a light pulse is emitted every three seconds. The setting mode is ended by a system start (+UB OFF/ON).

**3.4.2 Setting mode with cable connection 4-pole**

- 1) Receiver connection, connect Pin 1 (24V DC) with Pin 2 (OSSD 1).
- 2) Receiver supply voltage ON
- 3) Status indicator signals (yellow):
  - No alignment present: A light pulse every 3 sec.;
  - Alignment signal present: Higher frequency light pulse;
  - Alignment optimal: Light pulse is continuous ON (fix sensors)
- 4) Receiver supply voltage OFF
- 5) Remove wire link Pin 1 and Pin 2
- 6) Receiver supply voltage ON (Setting mode deactivated)

**3.5 Safety distance**

The safety distance is the minimum distance between the protection field of the safety light curtain and the hazardous area. The safety distance must be observed to ensure that the hazardous area cannot be reached before the hazardous movement has come to standstill.

**Calculation of the safety distance to EN ISO 13855 and EN ISO 13857**

The safety distance depends on the following elements:

- Stopping time of the machine (calculation by run-on time measurement)
- Response time of the machine and the safety light curtain and the downstream safety-monitoring module (entire safety guard)
- Approach speed
- Resolution of the safety light curtain

**Safety light curtain SLC440COM**

The safety distance for resolutions 14 mm up to 40 mm is calculated by means of the following formula:

**(1)  $S = 2000 \text{ mm/s} * T + 8 (d - 14) \text{ [mm]}$**

S = Safety distance [mm]  
 T = Total reaction time (machine run-on time, reaction time of the safety guard, relays, etc.)  
 d = Resolution of the safety light curtain

The approach speed is covered with a value of 2000 mm/s. If value S ≤ 500 mm after the calculation of the safety distance, then use this value.

If value  $S \geq 500 \text{ mm}$ , recalculate the distance:

**(2)  $S = 1600 \text{ mm/s} * T + 8 (d - 14) \text{ [mm]}$**

If the new value  $S > 500 \text{ mm}$ , use this value as safety distance.  
 If the new value  $S < 500 \text{ mm}$ , use a minimum distance of 500 mm.

**Example:**

Response time of the safety light curtain = 10 ms  
 Resolution of the safety light curtain = 14 mm  
 Stopping time of the machine = 330 ms

**$S = 2000 \text{ mm/s} * (330 \text{ ms} + 10 \text{ ms}) + 8(14 \text{ mm} - 14 \text{ mm})$**   
 **$S = 680 \text{ mm}$**   
 **$S > 500 \text{ mm}$ , therefore new calculation with  $V = 1600 \text{ mm/s}$**   
 **$S = 544 \text{ mm}$**

**Safety distance to the hazardous area**

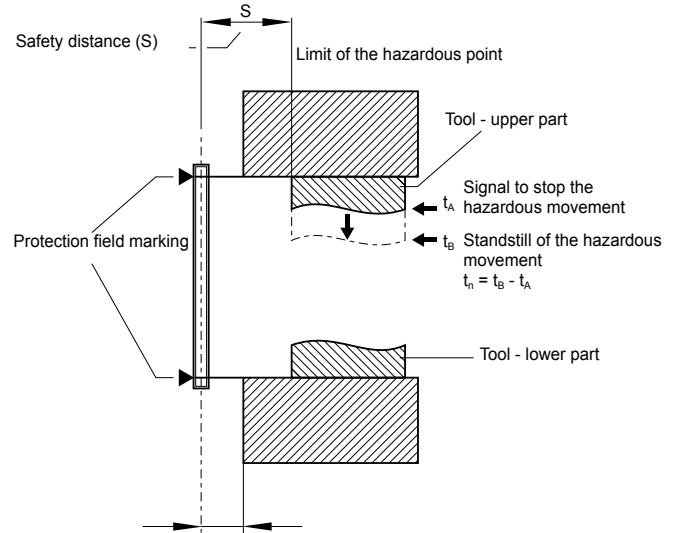

≤ 75 mm = max. distance for protection against stepping over  
 To prevent persons from stepping over the protection field this dimension must be imperatively respected and observed.

**Calculation of the safety distance for the multi-beam light grid SLG440COM**

**$S = (1600 \text{ mm/s} * T) + 850 \text{ mm}$**

S = Safety distance [mm]  
 T = Total reaction time (machine run-on time, reaction time of the safety guard, relays, etc.)  
 K = Approach speed 1600 mm/s  
 C = Safety supplement 850 mm

**Example**

Reaction time of the SLG440COM = 10 ms  
 Stopping time of the machine T = 170 ms

**$S = 1600 \text{ mm/s} * (170 \text{ ms} + 10 \text{ ms}) + 850 \text{ mm}$**   
 **$S = 1138 \text{ mm}$**

The following mounting heights must be observed:

Number of beams	Mounting height above reference floor in mm
2	400, 900
3	300, 700, 1100
4	300, 600, 900, 1200



Safety distance to the hazardous area

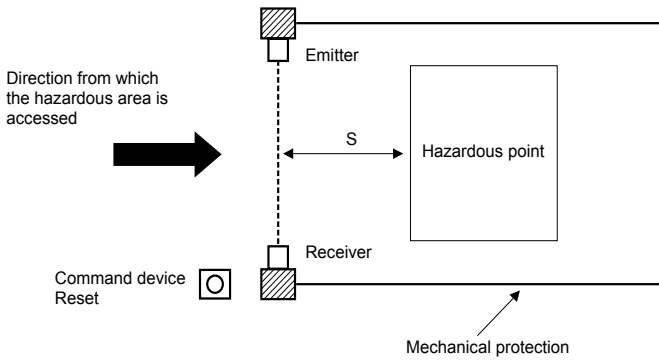

The formulae and calculation examples are related to the vertical set-up (refer to drawing) of the safety light grid with regard to the hazardous point. Please observe the applicable harmonised EN standards and possible applicable national regulations.

**!** The safety distance between the safety light curtain / light grid and the hazardous point must always be respected and observed. If a person reaches the hazardous point before the hazardous movement has come to a standstill, he or she is exposed to serious injuries.

**i** To calculate the minimum distances of the safety guards with regards to the hazardous point, the EN ISO 13855 and EN ISO 13857 must be observed. If an overlap of the protection field is possible, take care with the calculation of the safety distance referring to additional CRO according to the table A1 as per norm EN ISO 13855.

3.5.1 Minimum distance to reflecting surfaces

During the installation, the effects of reflecting surfaces must be taken into account. In case of an incorrect installation, interruptions of the protection field could possibly not be detected, which could lead to serious injuries. The hereafter-specified minimum distances with regard to reflecting surfaces (metal walls, floors, ceilings or parts) must be imperatively observed.

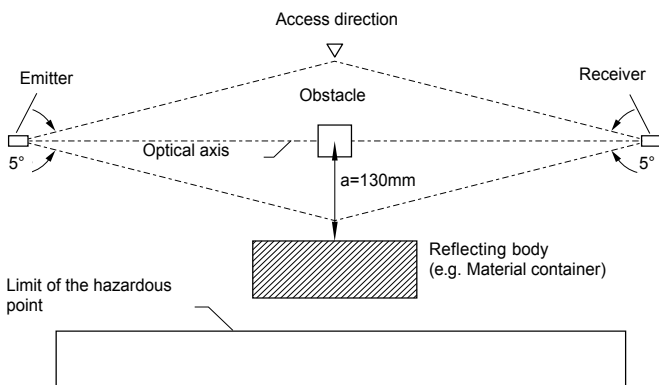

Safety distance a

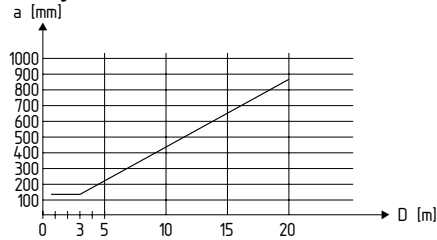

Calculate the minimum distance to reflecting surfaces as a function of the distance with an aperture angles of  $\pm 2.5^\circ$  degrees or use the value from the table below:

Distance between emitter and receiver [m]	Minimum distance a [mm]
0.2 ... 3.0	130
4	175
5	220
7	310
10	440
12	530

Formula:  $a = \tan 2.5^\circ \times L$  [mm]

a = Minimum distance to reflecting surfaces  
L = Distance between emitter and receiver

3.6 Mounting

The SLC/SLG440COM should be installed in such a way that interference with neighbouring safety light barriers / grids of the same type (SLC/SLG440COM) is excluded.

If two or more applications are arranged so that mutual interference is possible, this should be eliminated with a partition.

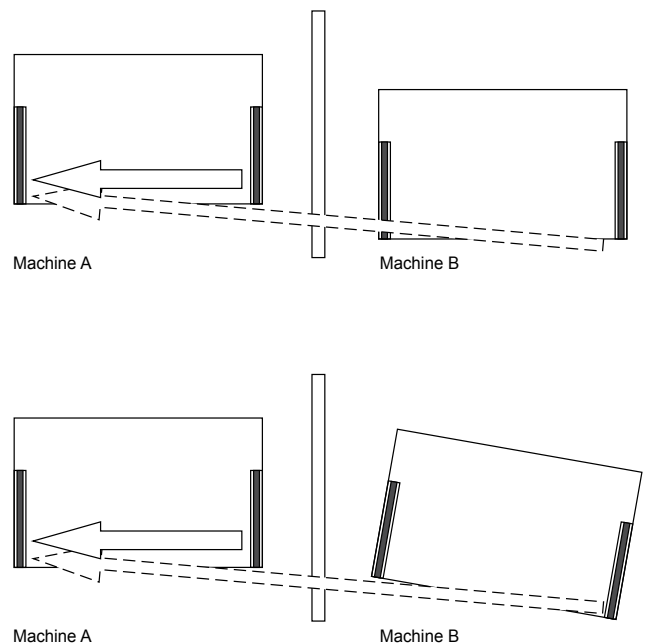

**i** Mutual interference of the sensors is to be prevented through appropriate installation. If this is not guaranteed, contact the manufacturer.

3.7 Dimensions

3.7.1 Dimensions emitter and receiver SLC440COM

All measurements in mm.

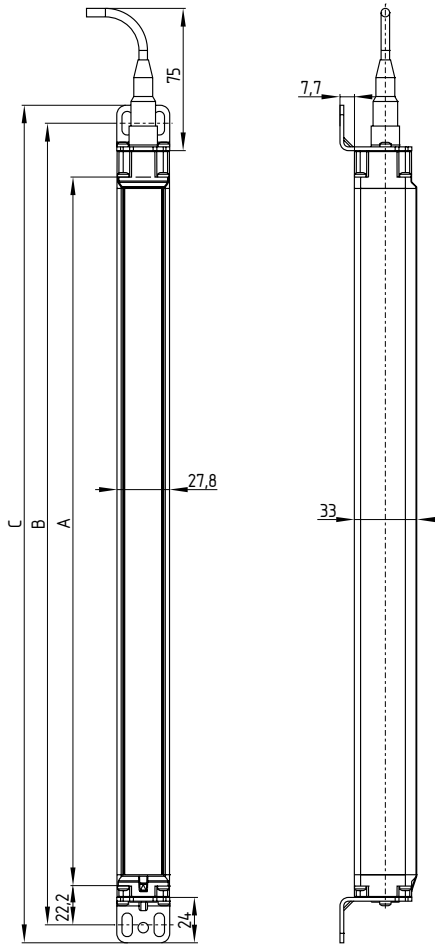

Type	A Protected height ± 1	B Mounting dimension ± 1	C Total length ± 1
SLC440COM-ER-0330-XX	330	384	403
SLC440COM-ER-0410-XX	410	464	483
SLC440COM-ER-0490-XX	490	544	563
SLC440COM-ER-0570-XX	570	624	643
SLC440COM-ER-0650-XX	650	704	723
SLC440COM-ER-0730-XX	730	784	803
SLC440COM-ER-0810-XX	810	864	883
SLC440COM-ER-0890-XX	890	944	963
SLC440COM-ER-0970-XX	970	1024	1043
SLC440COM-ER-1050-XX	1050	1104	1123
SLC440COM-ER-1130-XX	1130	1184	1203
SLC440COM-ER-1210-XX	1210	1264	1283
SLC440COM-ER-1290-XX	1290	1344	1363
SLC440COM-ER-1370-XX	1370	1424	1443
SLC440COM-ER-1450-XX	1450	1504	1523
SLC440COM-ER-1530-XX	1530	1584	1603
SLC440COM-ER-1610-XX	1610	1664	1683
SLC440COM-ER-1690-XX	1690	1744	1763
SLC440COM-ER-1770-XX	1770	1824	1843
SLC440COM-ER-1850-XX	1850	1904	1923
SLC440COM-ER-1930-XX	1930	1984	2003

3.7.2 Dimensions emitter and receiver SLG440COM

All measurements in mm.

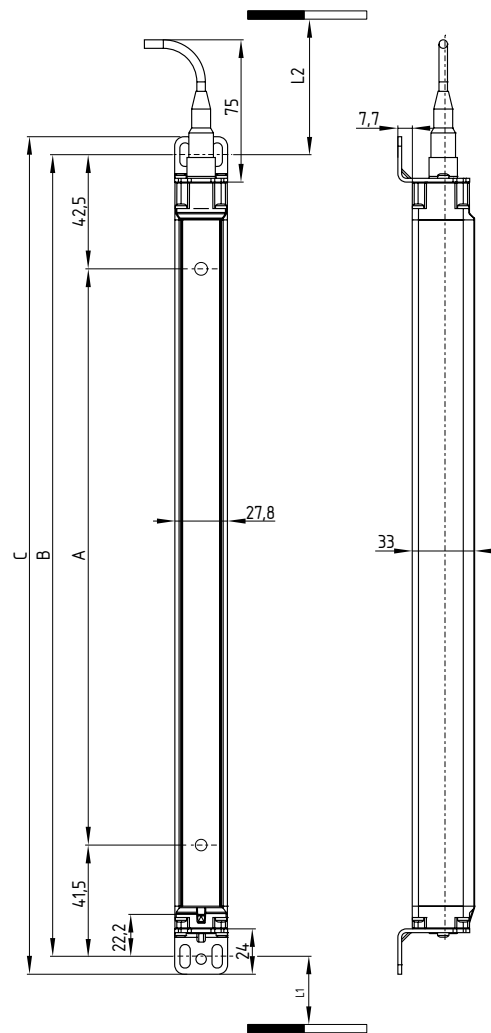

Type	A Beam dis- tance	B Moun- ting dimen- sion	C Total length	L1	L2
SLG440COM-ER-0500-02	500	584	603	358.5	357.5
SLG440COM-ER-0800-03	400	884	903	258.5	257.5
SLG440COM-ER-0900-04	300	984	1003	258.5	257.5

L1 = Mounting distance (mm) between floor and slotted hole centre (short end cap)

L2 = Mounting distance (mm) between floor and slotted hole centre (diagnostic window)

The overall length Ls (dimension end cap with regard to the cable connection up to the connector M12) of the sensors is calculated in the following way:

$$Ls = \text{size B} - 13 \text{ mm}$$

Example: SLC440COM-ER-0970-xx

$$Ls = 1024 - 13 = 1011 \text{ mm}$$

### 3.8 Fixing

#### 3.8.1 Included in delivery

##### Mounting kit MS-1100

The mounting kit consists of 4 steel angles and 8 fixing screws (Type Torx plus 10IP).

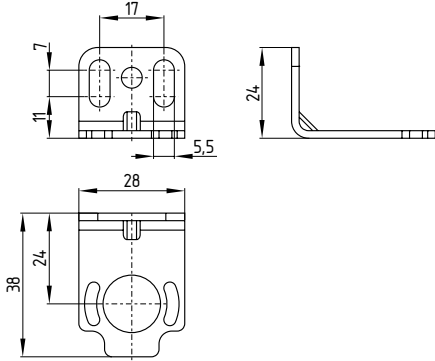

##### Integrated status indication

The status indication at the receiver indicates the switching condition of the outputs OSSD1 and OSSD2.

Green = Outputs in ON state (H-signal 24V)

Red = Outputs in OFF state (L-signal 0V)

Yellow = Restart Interlock released / Setting mode

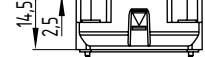

##### MSD5 spacer

The kit consists of 2 spacers. Available as of a protection zone height of 1050 mm. Mounting must be used in case of vibrations.

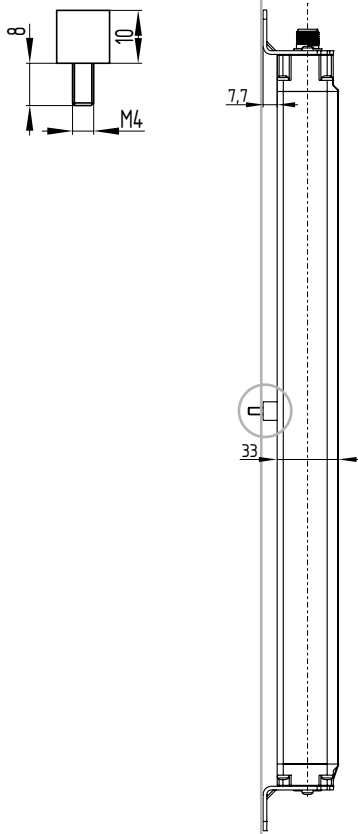

#### 3.8.2 Optional accessories

##### Centre support MS-1110

Mounting kit consists of 2 steel angles and 4 spacers for central fixing

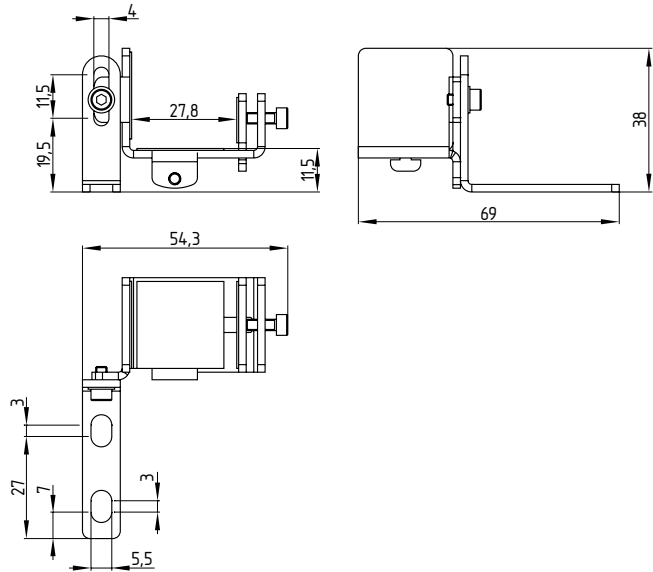

##### Connecting cable for emitter / receiver (4-pole)

Item Number	Designation	Description	Length
101207741	KA-0804	Female connector M12, 4-pole	5 m
101207742	KA-0805	Female connector M12, 4-pole	10 m
101207743	KA-0808	Female connector M12, 4-pole	20 m

##### Connecting cable for receiver (5-pole)\*

Item Number	Designation	Description	Length
101209949	A-K5P-M12-S-G-5M-BK-2-X-A-1	Female connector M12, 5-pole	5 m
101209948	A-K5P-M12-S-G-15M-BK-2-X-A-1	Female connector M12, 5-pole	15 m

\* For use in the operating mode Restart Interlock (manual reset)

##### Test rod PLS

The test rod is used for testing the protection field.

##### MSD4 Vibration damper

Kit consists of: 8 vibration dampers 15 x 20 mm, 8 M5 cylinder head screws with hexagon socket, 8 spring washers. Mounting using MS-1100.

The MSD4 vibration damper kit is recommend to be used for damping vibrations and oscillations on the SLC/SLG440COM. For applications with higher mechanical stresses, e.g. presses, punching machines, we recommend the MSD4 kit. In this way, the availability of the SLC/SLG440COM is increased.



4. Rear side Electrical connection

4.1 Wiring example SLC/SLG440COM

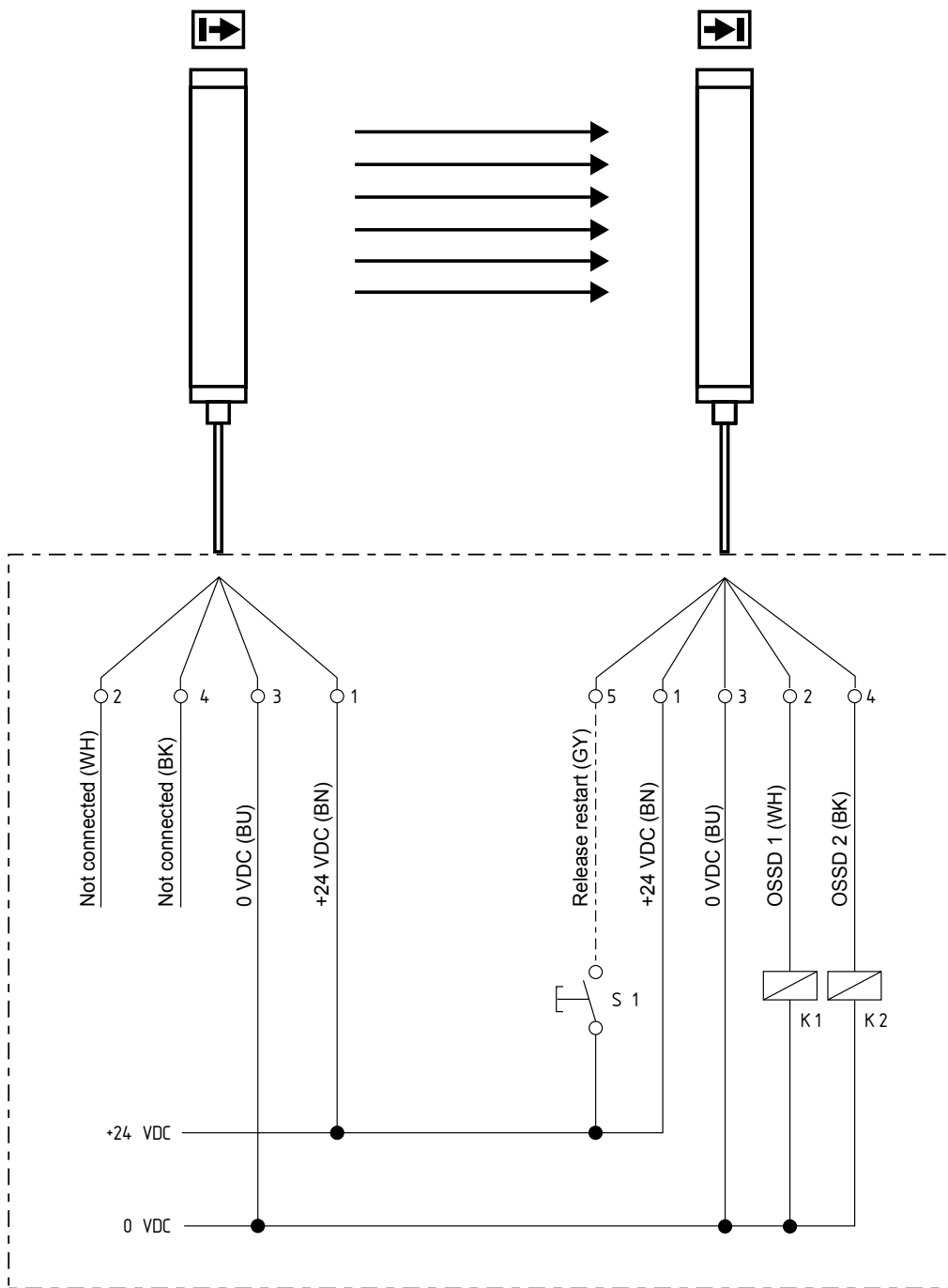

**Protective mode / Automatic active:**  
 Delivery state (Pushbutton S1 not connected)

**Restart Interlock (manual reset) active:**  
 Refer to the chapter: operating mode activate restart interlock  
 (Pushbutton 1 connected)

K1, K2: Relay for processing the switching outputs  
 OSSD 1, OSSD 2  
 S1: Pushbutton for restart (optional)

#### 4.2 Wiring example with safety-monitor module

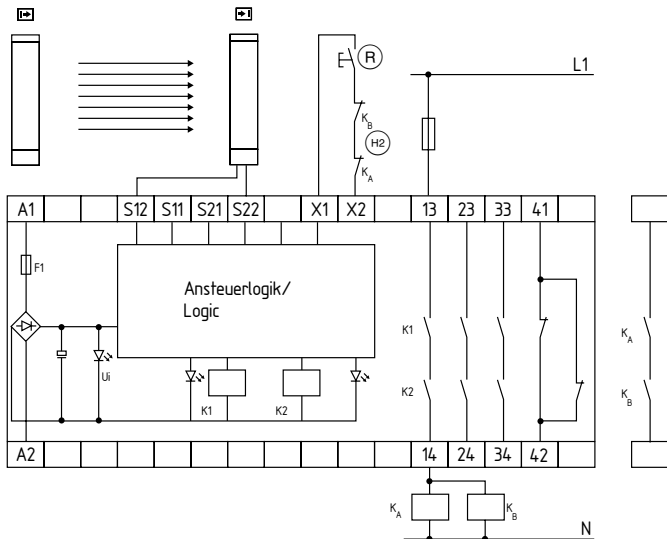

#### Key safety monitoring module

- Contactor control  $K_A$  and  $K_B$  at X1/X2
- Command device  $\text{\textcircled{R}}$  Restart interlock restart at X1/X2
- OSSD outputs at S12 and S22
- QS-switch = nQS, deactivate cross-wire short detection

#### 4.3 Connector configuration Receiver, Emitter & Cable

##### RECEIVER

##### SLC Connector

##### M12, 5-pole

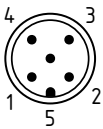

Designation	Description
1 BN 24 VDC	Power supply
2 WH OSSD 1	Safety output 1
3 BU 0 VDC	Power supply
4 BK OSSD 2	Safety output 2
5 GY Release/restart interlock	Acknowledgement restart interlock

##### Cable:

##### Connector female

##### M12, 5-pole

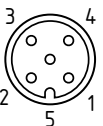

**i** It is possible to use the Automatic operating mode with a 4-pole cable (without pin 5 restart interlock).

##### EMITTER

##### SLC Connector

##### M12, 4-pole

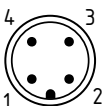

Designation	Description
1 BN 24 VDC	Power supply
2 WH Not used	Do not connect a signal (do not wire)
3 BU 0 VDC	Power supply
4 BK Not used	Do not connect a signal (do not wire)

##### Cable:

##### Connector female

##### M12, 4-pole

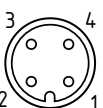

The colour codes are only valid for the cable types mentioned below "optional accessories".



For UL evaluated products we do recommend to use the UL style cable 20549.

## 5. Set-up and maintenance

### 5.1 Check before start-up

Prior to start-up, the following items must be checked by the responsible person.

#### Wiring check prior to start-up

1. The voltage supply is a 24V direct current power supply (see technical specifications), which meets the CE Directives, Low Voltage Directives. A power downtime of 20 ms must be bridged.
2. Presence of a voltage supply with correct polarity at the SLC/SLG.
3. The connecting cable of the emitter is correctly connected to the emitter and the connecting cable of the receiver correctly to the receiver.
4. The double insulation between the light curtain output and an external potential is guaranteed.
5. The outputs OSSD1 and OSSD2 are not connected to +24 VDC.
6. The connected switching elements (load) are not connected to +24 VDC.
7. If two or more SLC/SLG units are used within close range to each other, an alternating arrangement must be observed. Any mutual interference of the systems must be prevented.

#### Switch the SLC/SLG on and check the operation in the following way:

The component performs a system test during approx. 2 seconds after the operating voltage has been switched on. After that, the outputs are enabled if the protection field is not interrupted. The status indication at the receiver is on.



In case of incorrect functionality, please follow the instructions listed in the chapter Fault diagnostic.

### 5.2 Maintenance



Do not use the SLC/SLG before the next inspection is terminated. An incorrect inspection can lead to serious and mortal injuries.

#### Conditions

For safety reasons, all inspection results must be archived. The operating principle of the SLC/SLG and the machine must be known in order to be able conducting an inspection. If the fitter, the planning technician and the operator are different persons, please make sure that the user has the necessary information at his disposal to be able conduct the maintenance.

**5.3 Regular check**

A regular visual inspection and functional test, including the following steps, is recommended:

1. The component does not have any visible damages.
2. The optics cover is not scratched or soiled.
3. Hazardous machinery parts can only be accessed by passing through the protection field of the SLC/SLG.
4. The staff remains within the detection area, when works are conducted on hazardous machinery parts.
5. The safety distance of the application exceeds the mathematically calculated one.

**Operate the machine and check whether the hazardous movement stops under the hereafter mentioned circumstances.**

1. Hazardous machine parts do not move when the protection field is interrupted.
2. The hazardous machine movement is immediately stopped, when the protection field is interrupted with the test rod immediately before the emitter, immediately before the receiver and in the middle between the emitter and the receiver.
3. No hazardous machine movement when the test rod is within the protection field.
4. The hazardous machine movement comes to standstill, when the voltage supply of the SLC/SLG is switched off.

**5.4 Half-yearly inspection**

The following items must be checked every six months or when a machine setting is changed.

1. Machine stops or does not inhibit any safety function.
2. No machine modification or connection change, which affects the safety system, has taken place.
3. The outputs of the SLC/SLG are correctly connected to the machine.
4. The total response time of the machine does not exceed the response time calculated during the first putting into operation.
5. The cables, the connectors, the caps and the mounting angles are in perfect condition.

**5.5 Cleaning**

If the optics cover of the sensors is extremely soiled, the OSSD outputs can be disabled. Clean with a clean, soft cloth with low pressure. The use of aggressive, abrasive or scratching cleaning agents, which could attack the surface, is prohibited.

**6. Diagnostic**

**6.1 Status information**

Signalisation of the status occurs at the receiver end cap (the transmitter has no status indicator).

For status indication the following three colours are available:

- Red
- Yellow
- Green

**Status display**

Receiver end cap	Status	Description
OSSD ON	Green	Protection field clear
OSSD OFF	Red	Protection field interrupted
	Red with interruptions	Normal operation: System of configuration fault, see point 6.2
	Red flashing	Operation mode selection: Check operation mode
Restart	Yellow	Restart interlock (manual reset) active, signal expected at input restart interlock
	Yellow flashing	Setting mode: signal quality

**6.2 Fault diagnostic**

The status indication lights up permanently and indicates the fault number every second with short pulses.

Status display	Fault feature
1 impulse	Wiring fault
2 impulses	Voltage fault, check the supply voltage
3 impulses	Error output OSSD1 or OSSD2
4 impulses	Internal error diagnostic
6 impulses	Incorrect configuration data
7 impulses	Other internal fault

**7. Disassembly and disposal**

**7.1 Disassembly**

The safety switchgear must be disassembled in a de-energised condition only.

**7.2 Disposal**

The safety switchgear must be disposed of in an appropriate manner in accordance with the national prescriptions and legislations.

**8. Appendix**

**8.1 Contact**

**Consultancy / Sales:**



K.A. Schmersal GmbH & Co. KG  
 Möddinghofe 30  
 D-42279 Wuppertal  
 Tel.: +49 (0)2 02 - 64 74 - 0  
 Fax: +49 (0)2 02 - 64 74 - 100

You will also find detailed information regarding our product variety on our website: [www.schmersal.com](http://www.schmersal.com)

**Repair handling / shipping:**

Safety Control GmbH  
 Am Industriepark 2a  
 D-84453 Mühldorf/ Inn  
 Tel.: +49 (0) 86 31 - 1 87 96 - 0  
 Fax: +49 (0) 86 31 - 1 87 96 - 1

9. EU Declaration of conformity

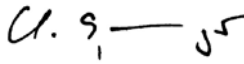
<b>EU Declaration of conformity</b>		
Original	Safety Control GmbH Am Industriepark 2a 84453 Mühldorf / Inn Germany	
We hereby certify that the hereafter described components both in their basic design and construction conform to the applicable European Directives.		
<b>Name of the component:</b>	SLC440COM SLG440COM	
<b>Type:</b>	See ordering code	
<b>Description of the component:</b>	Safety light curtain / safety light grid	
<b>Relevant Directives:</b>	Machinery Directive EMC-Directive RoHS-Directive	2006/42/EC 2014/30/EU 2011/65/EU
<b>Applied standards:</b>	EN 61496-1:2013, EN 61496-2:2013, EN ISO 13849-1:2008 + AC:2009, EN 62061:2005 + A1:2013	
<b>Notified body for the prototype test:</b>	TÜV NORD CERT GmbH Langemarckstr. 20, 45141 Essen ID n°: 0044	
<b>EC-prototype test certificate:</b>	44 205 13144609	
<b>Person authorised for the compilation of the technical documentation:</b>	Oliver Wacker Möddinghofe 30 42279 Wuppertal	
<b>Place and date of issue:</b>	Mühldorf, August 11, 2017	
SLC-SLG440COM-D-EN		
	Authorised signature <b>Klaus Schuster</b> Managing Director	Authorised signature <b>Christian Spranger</b> Managing Director



The currently valid declaration of conformity can be downloaded from the internet at [www.schmersal.net](http://www.schmersal.net).



**K. A. Schmersal GmbH & Co. KG**  
Möddinghofe 30, D - 42279 Wuppertal  
Postfach 24 02 63, D - 42232 Wuppertal

Phone: +49 - (0)2 02 - 64 74 - 0  
Telefax: +49 - (0)2 02 - 64 74 - 1 00  
E-Mail: [info@schmersal.com](mailto:info@schmersal.com)  
Internet: <http://www.schmersal.com>